

ENGINE POWERED TELESCOPIC BOOM LIFTS

TB660J PLUS

Compliant with ANSI/CSA standards

PRODUCT HIGHLIGHTS

Plus Series High Capacity

- Carry up to 3 occupants, materials, and tools with max platform capacity of 1,000 lb

Robust Design

- Heavy-duty steel construction and reinforced steering linkage provide unmatched durability and reliability

Intelligent Maintenance

- Industry-leading 7-inch screen and OTA functionality, providing the technicians with convenient access to live machine and maintenance information



Standard Features		
Automatic Platform Leveling	7" Color display screen	Dual-speed drive motor
Platform 160° hydraulic rotation	Safety controller	Patented anti-slip system by flow divider/combiner valve
Drive enable system	Fault diagnosis system	Foam-filled tires
Fully proportional controls	Swing-out engine	4-wheel brake
Horn and buzzer alarms	Engine restart protection	Hydraulic cylinder protective covers
Flashing beacon	Engine malfunction automatic shutdown	4WDx2WS
Tilt protection	Engine preheating	Full-time oscillating front axle
Overload sensing system	Emergency stop system	360° continuous turntable rotation
Max allowable inclination up to 5°	Auxiliary emergency lowering system	AC power to the platform
Optional Features		
4' 9" (1.45m) work platform	Anti-crush device	Telematics
6' (1.83m) work platform	Hydraulic generator	Platform work lights
8' 1" (2.44m) swing type tri-gate platform	Overhead anti-collision device	Solid non-marking tires
Foam-filled non-marking tires		

SINOBOOM™
— NORTH AMERICA

PARTNERS IN ACCESS™

SINOBOOM.US | INFO@SINOBOOM.US
105 W RILEY ROAD, HOUSTON TX 77047

ENGINE POWERED TELESCOPIC BOOM LIFTS

TB660J PLUS

Compliant with ANSI/CSA standards

Model	TB660J Plus
Dimensions	
Max Working Height	71' 7" (21.8m)
Max Platform Height	65' 7" (20.0m)
Max Horizontal Extension (Restricted/Unrestricted)	47' 11" (14.6m) / 52' 10" (16.1m)
A-Length Stowed	32' 9" (9.99m)
B-Width Stowed	8' 2" (2.49m)
C-Height Stowed	9' 2" (2.79m)
D-Wheelbase	8' 2" (2.49m)
Ground Clearance	1' 6" (0.46m)
Platform Dimensions (LxWxH)	8' x 3' x 3' 7" (2.44m x 0.91m x 1.1m)
Performance	
Platform Capacity (Restricted/Unrestricted)	1,000lbs (454kg) / 661lbs (300kg)
Platform Occupants (Restricted/Unrestricted)	3 persons / 2 persons
Turntable Rotation	360° Continuous
Platform Rotation	160°
Drive Speed - Stowed	3mph (4.8km/h)
Drive Speed - Raised	0.68mph (1.1km/h)
Gradeability (4WD)	45%
Turning Radius (Inside/Outside)	7' 10" (2.4m) / 18' 3" (5.55m)
Wind Resistance	28mph (12.5m/s)
Turntable Tailswing	4' 9" (1.45m)
Tilt Rating	5°
Drive x Steer	4WD x 2WS
Tire Size/Type	355/65D625 (Foam-filled)
Power	
Engine	36.4kW/2600rpm/D2.9 L4 T4f/Deutz/EPA T4
Hydraulic Tank Capacity	47.6 gal (US) (180L)
Fuel Tank Capacity - Diesel	42.3 gal (US) (160L)
System Voltage	12V DC
Batteries	2x12V, 220 Ah
Weight	
Weight	26,235lbs (11,900kg)

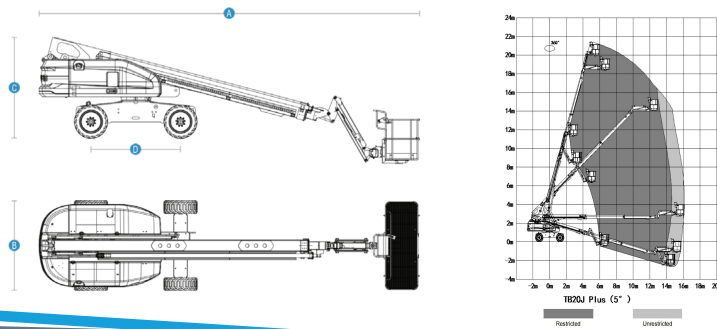

SINOBOOM™
NORTH AMERICA

PARTNERS IN ACCESS™